

**GO**

Van Marcke

# INSTRUCTION MANUAL

## Cold water tap Time delayed tap

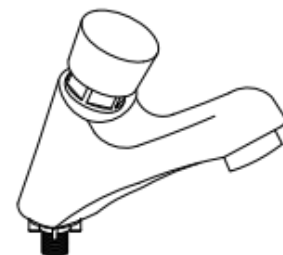
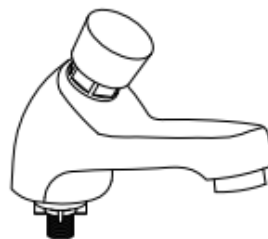
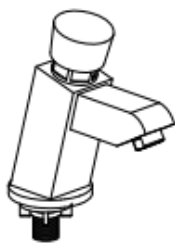
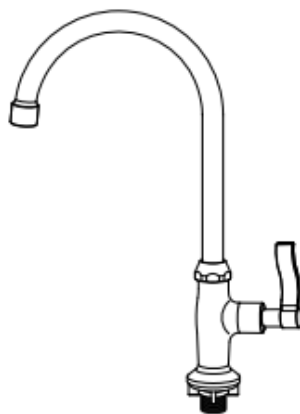
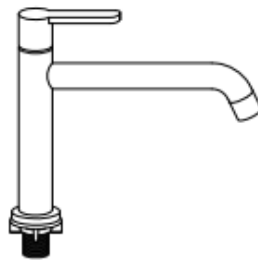
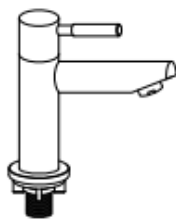

## 1 NOTES FOR INSTALLATION

- 1) Please do not connect hot and cold water supply lines in reverse. This could result in hot water flowing from cold line and cause scalding.
  - 2) The feed-water temperature of water shall not exceed 85°C. Exceeding 85° may cause scalding, the service life of faucets might be shortened, or the faucet might be damaged.
  - 3) The valve must be installed on the wall that is strong and thick enough.
  - 4) After installation, please make sure the faucet is securely mounted.
- ⚠ Warning: Read all the instructions completely before proceeding. We recommend calling a professional if you are uncertain about installing this product.

## 2 SHUT OFF WATER SUPPLY

Locate water supply inlet and shut off the water supply valves. These are usually found under the sink or near the water meter.

## 3 INSTALLATION

Make a hole with diameter 22mm on the deck 50mm from the edge of basin. And then insert the tap from hole.

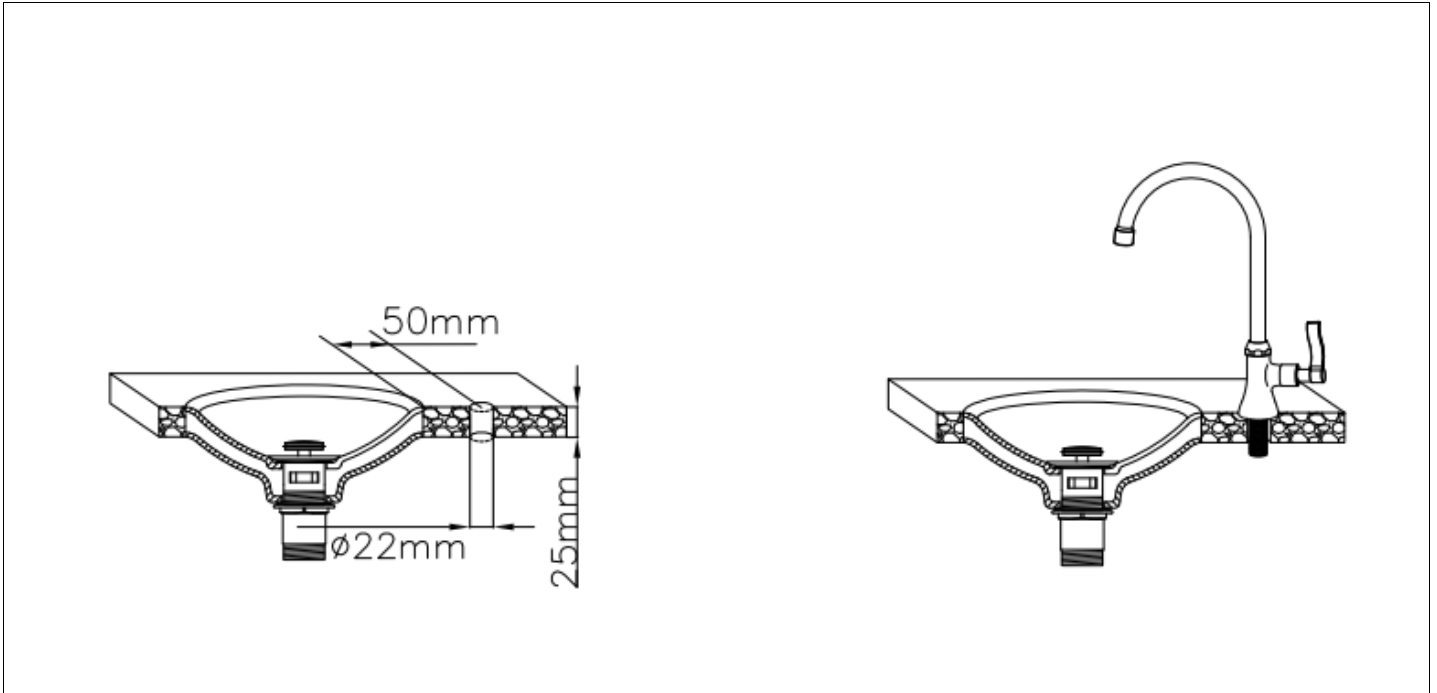

## 4 SECURING FAUCET

From underneath basin, secure Body by placing Rubber Washer and plastic Nut onto Connector assembled on the body. Tighten the plastic nut by tool. And connect the hose to the connect

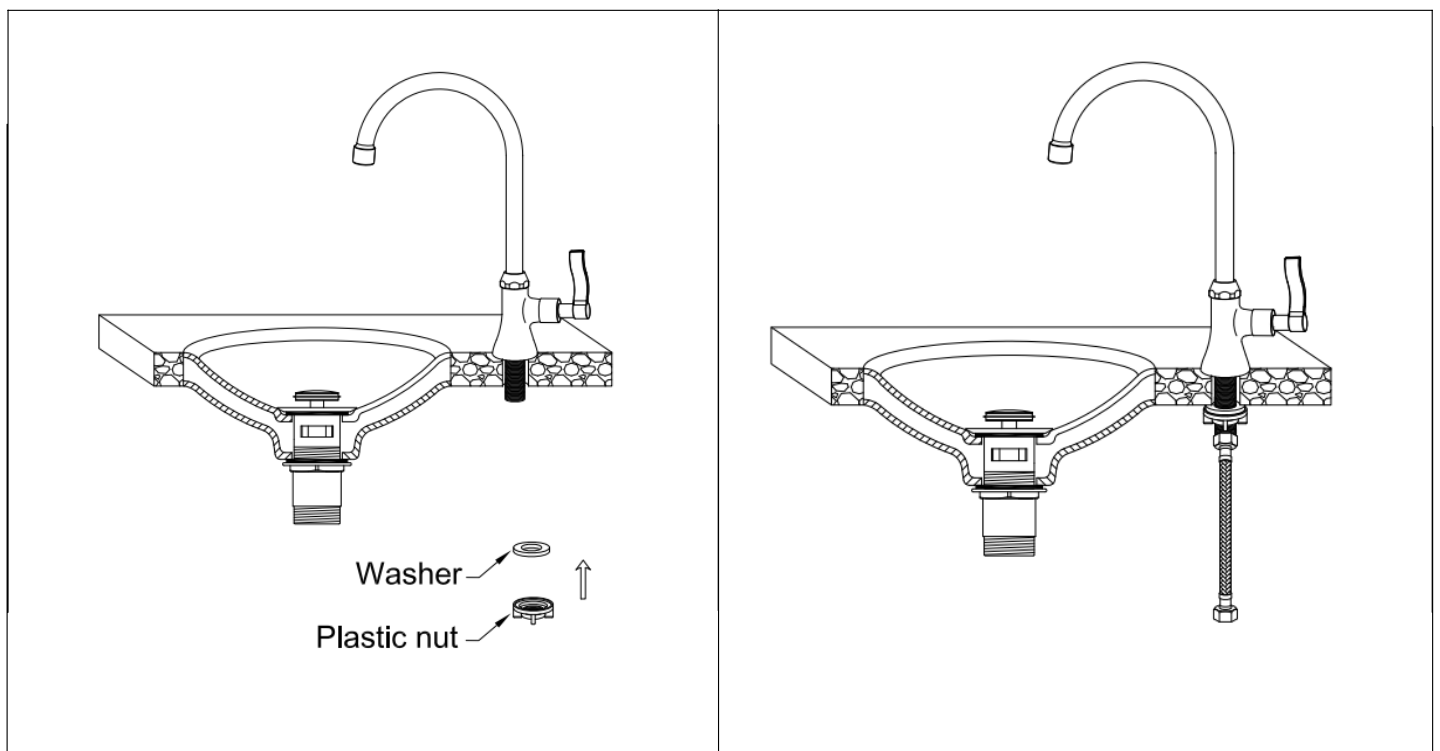

## 5 WATER SUPPLY LINES

Check if the washer is included into the connector of the flexible hose. Connect the flexible hose with angle valve.

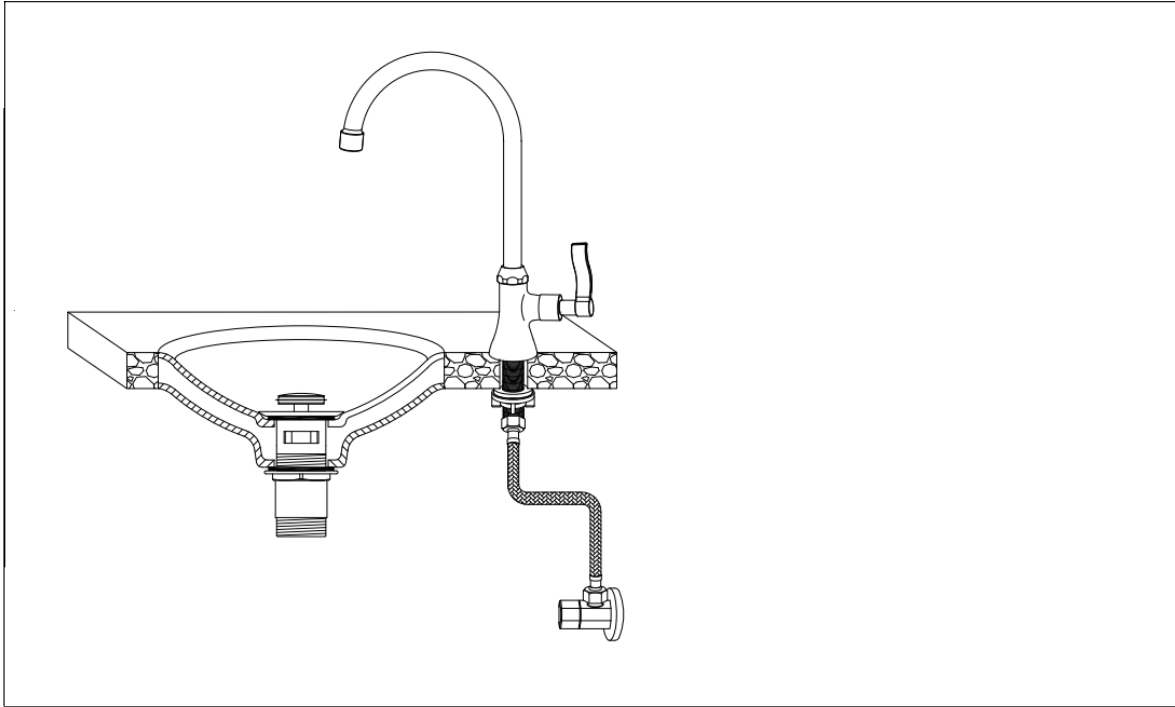

## 6 UNIT START UP

Turn on cold water supplies, and check for leaks above and below the basin.

## 7 VALVE FUNCTIONS

The way to turn on the tap as per below:

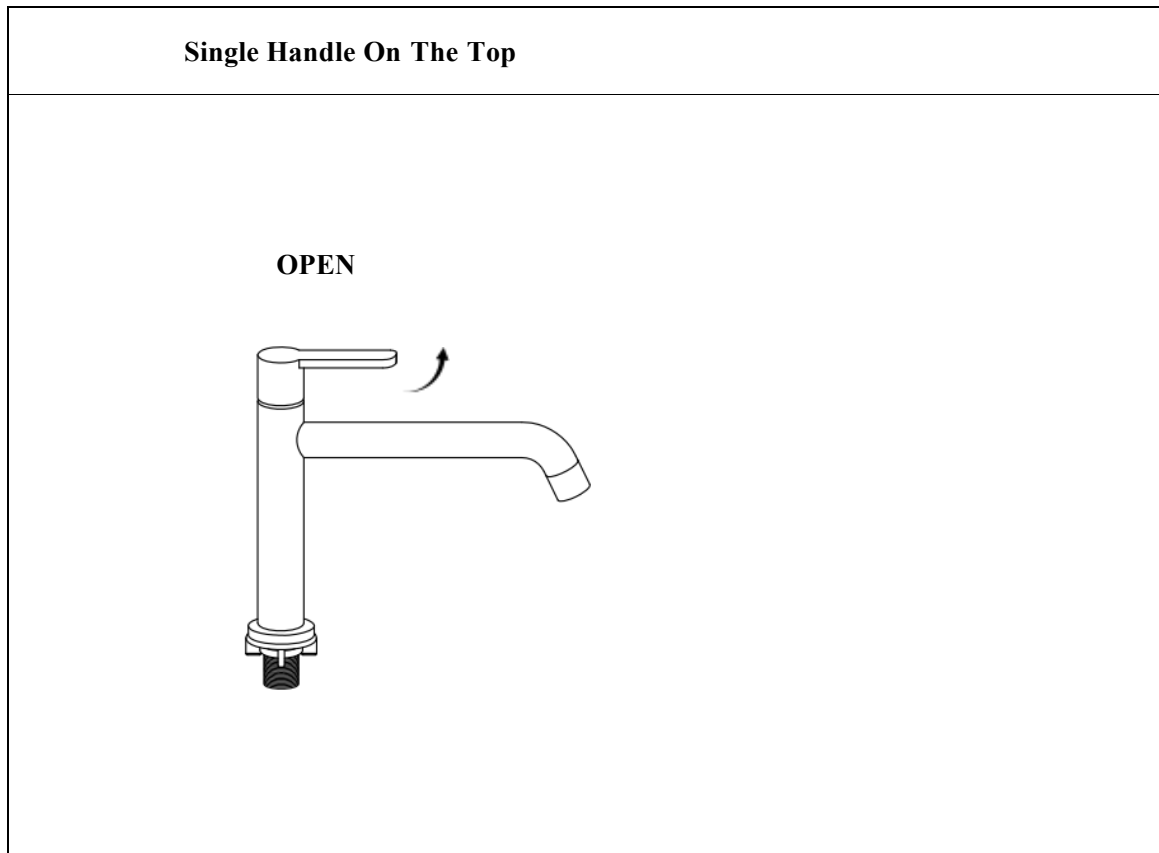

 **CAUTION: Maintenance**

The valves must be turned off to release the pressure of waterpipe during maintenance.

 **NOTE: Cleaning Instructions:**

For all decorative finishes, use only a soft damp cloth to clean and shine. Use of polish, detergents, abrasive cleaners, organic solvents or acid may cause damage. Use of other than a soft damp cloth will nullify our warranty.